

Macroscopic Quantum Phenomena and CP_2 Geometry

M. Pitkänen¹, February 1, 2006

¹ Department of Physical Sciences, High Energy Physics Division,
 PL 64, FIN-00014, University of Helsinki, Finland.
 matpitka@rock.helsinki.fi, <http://www.physics.helsinki.fi/~matpitka/>.
 Recent address: Puutarhurinkatu 10,10960, Hanko, Finland.

Contents

1	Introduction	3
2	General theory	3
2.1	Identification of the topological field quanta	4
2.2	Formation of the supra phase	5
2.2.1	Two-fluid picture topologically	5
2.2.2	Ground states for the supra phases	6
2.2.3	Binding energies and critical temperatures	8
2.3	Generalized quantization conditions	9
2.4	Dissipation in super fluids: critical velocities	10
2.4.1	Critical velocity for super fluids	10
2.4.2	Critical velocities for the super conductors	12
2.5	Meissner effect	13
2.5.1	Meissner effect in superconductors	13
2.5.2	Meissner effect for super fluids	15
2.5.3	Rotating super fluid	16
2.6	Phase slippage	18
3	Models for the topological field quanta	18
3.1	The Kähler field created by a constant mass density	19
3.2	The imbedding of a constant magnetic field	22
3.3	Magnetic fields associated with constant velocity flows	24

4	Quantum Hall effect from topological field quantization	24
4.1	The effect	24
4.2	The model	25
4.2.1	Conduction electrons as a mesoscopic quantum system	25
4.2.2	How to avoid the splitting of the joining along boundaries bonds in a strong magnetic field	25
4.2.3	Quantization conditions	26
4.2.4	Carriers of the Hall current as an incompressible 2-dimensional liquid	26
4.2.5	Stationary state	27
4.2.6	Hall current	27
4.2.7	Comments	28
5	TGD and condensed matter	28
5.1	Electronic conductivity and topological field quantization	28
5.2	Dielectrics and topological field quantization	29
5.3	Magnetism and topological field quantization	29

Abstract

Topological field quantization is applied to a unified description of three macroscopic quantum phases: super conductors, super fluids and quantum Hall phase. The basic observation is that the formation of the join along boundaries bonds makes possible the formation of macroscopic quantum system from topological field quanta having size of the order of the coherence length ξ for ordinary phase. The presence of the bridges (join along boundaries bonds) makes possible supra flow and the presence of two levels of the topological condensate explains the two-fluid picture of super fluids. In standard physics, the order parameter is constant in the ground state. In TGD context, the non-simply connected topology of the 3-surface makes possible ground states with a covariantly constant order parameter characterized by the integers telling the change of the order parameter along closed homotopically nontrivial loops.

The role of the ordinary magnetic field in super conductivity is taken by the Z^0 magnetic field in super fluidity and the mathematical descriptions of super conductors and super fluids become practically identical. The generalization of the quantization condition for the magnetic flux to a condition involving also a velocity circulation, plays a central role in the description of both phases and suggests a new description of the rotating super fluid and some new effects. A classical explanation for the fractional Quantum Hall effect in terms of the topological field quanta is proposed. Quantum Hall phase is very similar to the supra phases: an essential role is played by the generalized quantization condition and the hydrodynamic description of the Hall electrons.

The results obtained support the view that in condensed matter systems topological field quanta with size of the order of $\xi \simeq 10^{-8} - 10^{-7}$ meters are of special importance. This new length scale is expected to have also applications to less exotic phenomena of the condensed matter physics (the description of the conductors and di-electrics and ferromagnetism) and in hydrodynamics (the failure of the hydrodynamic approximation takes place at this length scale). These field quanta of course, correspond to only one condensate level and many length scales are expected to be present.

1 Introduction

Super conductivity, super fluidity and quantum Hall effect are examples of macroscopic quantum phenomena and it is instructive to apply the TGD inspired topological ideas about the formation of the macroscopic quantum systems to these phenomena. This chapter is written for about 15 years ago and I hope that the reader does not forget that much has occurred in TGD since then.

For instance, Z^0 magnetic fields are suggested to be important for understanding super fluidity without precise characterization of their origin. About 15 years after writing the first version of this chapter, it became clear that the source of the long ranged Z^0 fields, as well as other weak fields and color gauge fields predicted by the classical theory could be dark matter at various space-time sheets. Also a precise number theoretic characterization of dark matter, or actually infinite hierarchy of dark matters, emerged. Already earlier it had become clear that the theory predicts a fractal hierarchy of scaled down copies of electro-weak and color physics. I have not added any discussion of the origin of Z^0 classical gauge fields here. This kind of discussion can be found [?] and in [F6, F8, F9].

In the first section the general ideas of the TGD inspired description of supra phases are described. The aim is to make clear the close similarity between super conductivity and super fluidity by treating these phenomena in parallel. What makes possible the unified description is the hypothesis that the role of the ordinary magnetic field in the super conductivity is taken by the Z^0 magnetic field in the super fluid phase.

In the second, more technical section, certain simple imbeddings of Kähler electric and magnetic fields created by matter and relevant to the applications of the theory, are studied.

In the third section a TGD inspired phenomenological description of Quantum Hall effect is proposed. A more refined view about Quantum Hall effect developed about 15 years later can be found in [E9]. In the last section the TGD inspired description of less exotic condensed matter phenomena (conductors, di-electrics and magnetism) using TGD based concepts will be discussed briefly.

2 General theory

RGE invariance predicts that that 3-space should have fractal like structure consisting of topological field quanta of all possible sizes glued on each other by the topological sum operation. The join along

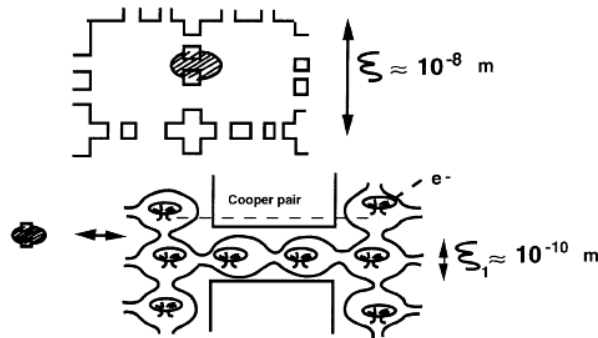

Figure 1: Schematic representation for super conductor

boundaries bond provides a tool for constructing larger quantum systems from the smaller ones. Since dissipation corresponds to a loss of the quantum coherence, join along boundaries bond should provide a key to a topological description of the dissipation. The generation of the long range classical Z^0 fields is a phenomenon characteristic for TGD, and is expected to be important in the small vacuum quantum number limit of TGD at the condensate levels $n \geq n_Z$ $L(n) \geq \xi \sim 10^{-6}$ m. For supra phases the correlation lengths are such that classical Z^0 force should not have any role in their description.

The mathematical similarities between super conductors and super liquids however suggest that Z^0 magnetic field might play same role in the description of dissipation of super fluids as ordinary magnetic field in the description of the super conductors. The many sheeted structure of the topological condensate and length scale hierarchy remains rather implicit in the following considerations and the most relevant condensation levels are 'atomic condensation level' at which electrons and nuclei are condensed and the level n_Z at which nuclei feed their Z^0 charges.

2.1 Identification of the topological field quanta

Both super conductors and Super fluids are characterized by the coherence length ξ . This length tells the size of the largest possible coherent quantum subsystem in the ordinary phase and becomes infinite, when the transition to the supra phase takes place. Below the critical point the value of ξ is finite, but there is macroscopic quantum coherence since the order parameter develops vacuum expectation value. Since topological field quanta correspond in TGD framework to coherent quantum systems a natural assumption is that the relevant topological field quanta have size of the order of ξ . ξ is typically of the order of $\xi \simeq 10^{-8} - 10^{-7}$ meters for super conductors, for super fluid He^4 ξ is of the order of atomic length scale and for He^3 ξ is of the order of 10^{-8} meters. This suggests that also ordinary matter behaves like supra phase in the length scales shorter than ξ . Of course, the corresponding time scale is rather short for the typical velocities of the supra flows.

In accordance with RGE hypothesis, it is assumed that topological field quanta of size ξ have suffered topological condensation in the background 3-space and topological field quanta in turn contain matter as topologically condensed 3-surfaces having size of atomic length scale (see Fig. 2.1 and 2.2 for a schematic description of what the supra phases look like). For super conductors the topological field quanta of atomic size have also joined along their boundaries to form a lattice.

The size of the topological field quantum is determined by the vacuum quantum numbers associated with it. Since the size of the topological field quantum is rather small, the values of the vacuum quantum ω_1, ω_2 must be small. A first principle explanation for the finite size of the topological field quantum is the maximization of Kähler function. The contribution of the Kähler electric field to the Kähler action is smaller in magnitude if topological field quantization takes place: the reason is that Kähler electric field necessarily vanishes at some point(s) inside the topological field quantum.

In the simplest model for a topological field quantum matter serves as a source of Kähler field, which in present case is purely electromagnetic field and possible due to the incomplete screening of

the nuclear electromagnetic charge by electrons. The critical radius associated with the imbedding of the Kähler electric field gives the size of the topological field quantum, which should be of the order of ξ . The simplest model for the field quantum is as a spherical region. The join along boundaries condensate of the topological field quanta serves as a model for the ordinary phase.

The sizes of the field quanta are exponentially sensitive to the value of the fractal quantum number m , which is small in present case. The order of magnitude for ω_1 is not much larger than proton mass: the estimates give $\omega_1 = (10^{2.5} - 10^3)m_p$ (m_p is proton mass). In the astrophysical length scales and possibly also in the background 3-space surrounding topological field quanta in question the value of ω_1 is of the order of $m_0 \sim 1/R \sim 10^{-4}m_{Pl}$, where R is CP_2 radius.

Inside each topological field quantum one must perform a choice of the quantization axis and in the ordinary phase these choices are not correlated in accordance with the idea that quantum coherence is lost. In supra phase the presence of the join along boundaries bonds implies that same choice of the quantization axis must be performed in the whole phase and the global choice of the quantization axis is analogous to that taking place in the quantum measurement.

2.2 Formation of the supra phase

Supra phase corresponds to lattice like structure of the topological field quanta of size ξ joined together by the join along boundaries bonds. In the lowest order approximation one can regard this lattice as a network formed by straight cylinders glued together by bonds. (see Fig. 2.1 and 2.2). In suprphase the quantum numbers n_1 associated with the composite field quanta must vanish identically since otherwise the coordinate Φ is discontinuous somewhere on the bond joining the neighbouring field quanta and the field quantum in question separates from the supra phase. Exception is formed by the direction of the quantization axis, where bonds survive.

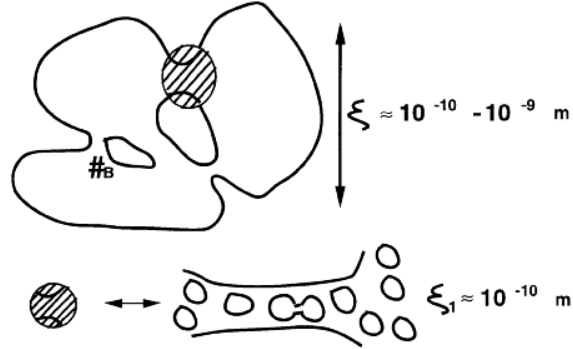

Figure 2: Schematic representation for Super Fluid

2.2.1 Two-fluid picture topologically

Supra flow is made possible by the bonds between the neighbouring topological field quanta and there is no essential difference between super conductors and super fluids in this respect. In case of the super conductors the topological field quanta form a rigid lattice but in case of super fluids topological field quanta are able to move. This freedom implies the two-fluid picture of the super fluidity (see Fig. 2.2) as the following argument shows.

1. Normal liquid corresponds to the topological field quanta (of size ξ), which flow in the background 3-space. Since the bonds are absent in the ordinary phase, the matter condensed on the topological field quanta follows the flow of the topological field quanta so that topological field quanta can be regarded as effective fluid particles and their mass density is that of the liquid:

$$\rho_n = \rho.$$

2. In supra phase the presence of the bonds make possible the flow of the topologically condensed matter and if the bonds are stable the condensed matter flows completely freely: $\rho_s = \rho$. This means that topological field quanta itself lose totally their inertia so that $\rho_n = 0$. Although the flow of the topological field quanta is possible it does not correspond to the flow of an inertial mass. This is certainly the situation at sufficiently low temperatures.
3. For temperatures slightly below T_c the situation is known to be intermediate between these two situations and two-fluid hydrodynamics [23] is a good phenomenological description of the situation. One can consider two alternative explanations for this state of affairs. The first explanation is that the fluid is a mixture of the normal and super fluid components not only in critical temperature but also little below it so that one can speak about two fluids with average densities satisfying the condition $\rho_n + \rho_s = \rho$. The second alternative is that for the temperatures close to T_c the bonds are not completely stable and condensed matter doesn't flow completely freely so that topological field quanta do not lose their inertia totally.
4. One can understand also the frictionless supra flow in this picture. For example, in the frictionless supra flow in a channel, the topological field quanta are at rest with respect to the walls of the channel and only the matter condensed on the field quanta flows.

It should be emphasized that in TGD framework it is not possible to apply two-fluid picture to the description of the electrons in Super conductors since the particles of the "normal fluid" correspond to topological field quanta rather than electrons or atoms.

2.2.2 Ground states for the supra phases

In the ground state of the super conductor, the order parameter is covariantly constant with respect to the covariant derivative defined by the electromagnetic gauge potential. Covariant constancy indeed makes sense since, in the absence of the magnetic fields, the gauge potential is pure gauge in the spatial degrees of freedom. In the standard physics context the first homotopy group of the 3-space is trivial and gauge potential can always be gauge transformed away so that the order parameter is just constant in the ground state. In TGD context, the first homotopy of 3-surface is nontrivial and very complicated for a join along boundaries condensate formed from the topological field quanta glued by the join along boundaries bonds. This implies that there is rich structure of different covariantly constant ground states, which look macroscopically identical since the splitting of single join along boundaries bond is not expected to affect the macroscopic properties of the system.

The induced gauge potential is in the case of the super conductors just the electromagnetic gauge potential. Assuming that Z^0 gauge fields are absent, one obtains the proportionality of the electromagnetic and Kähler gauge potentials:

$$A_{em} = 3A_K = 3P^k dQ_k . \quad (2.1)$$

Here P_k and Q_k are canonical coordinates for CP_2 . An especially natural choice for the canonical coordinates is the one for which Q_k , $k = 1, 2$ correspond to the phase angles Ψ and Φ associated with the complex CP_2 coordinates for which the action of $U(2)$ rotations is linear.

In case of the supra fluids Z^0 gauge potential if electromagnetic neutrality holds true and again the gauge potential is proportional to Kähler potential

$$\begin{aligned} A_Z &= \frac{6}{p} A_K = \frac{6}{p} P^k dQ_k , \\ p &\equiv \sin^2(\theta_W) . \end{aligned} \quad (2.2)$$

If the ground state has vanishing gauge field the induced Kähler field must vanish and one has vacuum extremal of the Kähler action satisfying

$$P_k = \partial_k f(Q_i) , \quad (2.3)$$

where f is arbitrary function of the coordinates Q_i . In case that Q_i correspond to the angle coordinates Ψ and Φ of CP_2 one can write $f(Q_i)$ as a sum of a zero mode part and Fourier expansion

$$f = m\Psi + n\Phi + \sum_{kl} c_{kl} \exp(ik\Psi + il\Phi) . \quad (2.4)$$

The covariant constancy condition for an order parameter possessing em (Z^0) charge Q_{em} (Q_Z) reads as

$$\begin{aligned} (\partial_\mu + ia\partial_\mu f)\psi &= 0 , \\ a_{em} &= 3Q_{em} , \\ a_Z &= \frac{6Q_Z}{p} . \end{aligned} \quad (2.5)$$

The solution of the condition is

$$\begin{aligned} \psi &= \exp(iS)\psi_0 , \\ S_{em} &= -3Q_{em}f , \\ S_Z &= -\frac{6Q_Z}{p}f . \end{aligned} \quad (2.6)$$

in the two cases respectively.

The phase increments around the closed homotopically nontrivial loops clearly characterize the ground state of the supra phase. In the electromagnetic case the change of the phase of ψ around a closed loop equals to

$$\Delta S_{em} = 3Q_{em}(m\Delta\Psi + n\Delta\Phi) , \quad (2.7)$$

and is clearly a multiple of 2π (also for quarks!) since m and n appearing in the expansion of f are in general integers. For supra fluids one has

$$\Delta S_Z = \frac{6Q_Z}{p}(m\Delta\Psi + n\Delta\Phi) , \quad (2.8)$$

The values of Q_Z for proton and neutron are $Q_Z(\text{neutron}) = -1/4$ and $Q_Z(\text{proton}) = 1/4 - p$ so that one has for an order parameter describing the supra flow of nuclei (A, Z)

$$\Delta S_Z = 6\left(\frac{(2Z - A)}{4p} - Z\right)(m\Delta\Psi + n\Delta\Phi) , \quad (2.9)$$

The increment is *not* integer multiple of 2π without additional conditions on the value of the Weinberg angle. If p is rational number of form $p = r/s$, s must divide m and n . For instance, for $\sin^2(\theta_W) = 1/4$ the vectorial couplings of the electron and proton to Z^0 field vanish and the average Z^0 charge of neutron is $Q_Z(n) = -1/4 = p$ so that one has in general $Q_Z(\text{nucleus}) = -(A - Z)/4$ and the increment of S_Z is automatically multiple of 2π for all choices of m and n :

$$\Delta S_Z = -6(A - Z)(m\Delta\Psi + n\Delta\Phi) . \quad (2.10)$$

Also for $p = 3/8$ the condition is identically satisfied.

For more complicated supra phases (Super liquid He^3) the order parameter possesses several components but also now a similar situation results. It is tempting to assume that for more general states the phase factor of ψ is power of S . If this is the case then supra phases are exceptional in the sense that CP_2 angle coordinates appear as physical observables rather than only the gauge fields (proportional to the gradients of CP_2 coordinates) as in the ordinary ordinary phase. What is clear is that the information about the homotopy of the state is coded into the phase of the order parameter. This state of affairs is especially interesting as far the applications to the BE condensate of the charged # throats possibly having an important role in bio-systems, are considered.

2.2.3 Binding energies and critical temperatures

What makes the supra flow possible are the bonds. Cooper pair also stabilize the bonds in case of the super conductors and ${}^3\text{He}$ super fluid. This becomes clear from the fact that the electrons of the Cooper pair have an average distance, which is considerably larger than ξ (about 10^{-6} meters in super conductors [23]) so that the splitting of the bonds destroys Cooper pairs. Energy is however needed to destroy Cooper pairs and this implies stability. If the energy associated with the bonds were negligible with the binding energy associated with the Cooper pairs the phase transition leading to super conducting phase would be a first order transition involving non-vanishing latent heat. This is however not the case [23]. This means that the binding energy of the Cooper pairs doesn't leave super conductor and probably goes to the energy associated with the bonds. Therefore the stabilization mechanism relies on the difficulty of transferring the bond energy to the Cooper pairs.

A rough estimate for the binding energy for the Cooper pair provides a test for the proposed ideas. In the ordinary phase conduction electrons tend to be confined inside the topological field quanta so that by Uncertainty Principle they possess kinetic energy of the order of

$$T \simeq \frac{1}{2m_e\xi^2} . \quad (2.11)$$

In the super conducting phase conduction electrons are not localized inside single field quantum so that the average kinetic energy is smaller and the order of magnitude estimate

$$\Delta E \simeq \frac{1}{4m_e\xi^2} , \quad (2.12)$$

for the binding energy of the Cooper pair is obtained. For $\xi \simeq 10^{-7}$ meters one obtains $\Delta E \simeq 10^{-4}eV$, which corresponds to the temperature of $T_c \simeq 0.25 K$. The order of magnitude is correct.

For a high temperature super conductors with $T_c \simeq 100 K$, the estimate gives $\xi \simeq 10^{-9}$ meters. High temperature super conductors have layered structure. In case of $YBa_2Cu_2O_7$ the coherence length is $\xi_c = 1.5 - 3$ Angströms in the direction orthogonal to the layers and $\xi_{ab} = 14 \pm 2$ Angströms in the direction of the layers [19]. The supra current is known to be confined inside the layers so that ξ_{ab} should determine the critical temperature: the orders of magnitude are consistent with the formula correlating Δ and ξ in the example considered and also more generally, since the transversal coherence lengths are known to be by an order of magnitude smaller than for the ordinary super conductors.

For the binding energy of the super fluid particles one obtains a completely analogous estimate (m_e is replaced with the mass of He^3 or He^4 nucleus) and correct order of magnitude estimates are obtained for both He^3 and He^4 having widely different values of ξ (ξ is about 10^{-8} meters and few Angströms for 4He and 3He respectively). From the binding energies one can estimate the critical temperatures ($T_c \simeq \Delta E$) and correct order of magnitude estimates are obtained.

The presence of super fluid phase in neutron stars has been suggested [23]: Cooper pairs correspond to paired neutrons. The size of the field quantum is of the order of $\xi = 10^{-15} - 10^{-14}$ meters (this estimate is derived in the second section). For the critical temperature one obtains: $T_c \simeq 1/4m_n\xi^2 = 10^{11} - 10^{13} K$.

In BCS theory ΔE is expressed in the following form [23]

$$\begin{aligned} \Delta &= 2\omega_D \exp\left(-\frac{2}{N(0)V}\right) , \\ \omega_D &= \frac{c_s 6^{1/3}\pi}{N^{1/3}} . \end{aligned} \quad (2.13)$$

Here ω_D is Debye frequency, $N(0)$ is the density of states on the surface of the Fermi sphere and $V(0)$ characterizes the strength of the attractive force between the electrons of the Cooper pair. N is the number density of atoms and c_s is the velocity sound. The proportionality to ω_D implies isotope effect: $\Delta \propto 1/A^\alpha$, where α is typically of the order of $\alpha \simeq 1/2$, which has been verified experimentally

[23]. Assuming that both formulas are correct one gets a relationship between the vacuum quantum numbers ω_1 and ω_2 since ξ corresponds to the radius of the topological field quantum and is expressible in terms of the vacuum quantum numbers.

2.3 Generalized quantization conditions

In the standard formulation of the quantum description of Super conductivity one starts from Schrödinger amplitude ψ_s for supra phase. The expression for the matrix element of the electric current is given by

$$\begin{aligned}\bar{j}_e &= -i\frac{e}{2m}(\bar{\psi}_s\bar{D}\psi_s - c.c.) , \\ \bar{D} &= \nabla + iqe\bar{A} .\end{aligned}\quad (2.14)$$

Here q denotes the charge of the superconducting charge carrier in units of e . $q = -2$ for the superconductors encountered in laboratory. One can write ψ_s in the form $\psi_s = \sqrt{n_s}\exp(iS)$.

Since n_s is in a good approximation constant in supra phase the expressions for the electric current and velocity operator can be written as

$$\begin{aligned}\bar{j}_e &= -\frac{e}{m}n_s(\nabla + qe\bar{A}) , \\ \bar{v}_s &= \frac{1}{m}(\nabla S + qe\bar{A}) .\end{aligned}\quad (2.15)$$

Since S is single valued, one obtains by integrating over a closed curve a formula relating the magnetic flux and velocity circulation for the carriers of the super current to each other.

$$\oint \bar{v} \cdot d\bar{l} - \frac{qe}{m} \oint \bar{A} \cdot d\bar{l} = \frac{n2\pi}{m} .\quad (2.16)$$

If the velocity field vanishes in the curve in question, one obtains the standard quantization of the magnetic flux.

By taking a curl of the formula for \bar{v}_s and using Maxwell's equations one gets the standard formula

$$\begin{aligned}\nabla^2\bar{B} &= \frac{\bar{B}}{\lambda^2} , \\ \lambda^2 &= \frac{2m}{n_sq^2e^2} .\end{aligned}\quad (2.17)$$

Here λ is the penetration length for the magnetic field in the super conductor.

TGD predicts that vacuum Z^0 field can become long ranged at small vacuum quantum number limit of TGD and super fluidity might correspond to this kind of situation. If this is indeed the case then the previous formulas for the super conductors generalize in an obvious manner to the case of Super fluids

$$\oint \bar{v} \cdot d\bar{l} - \frac{Q_Z g_Z}{M} \oint \bar{A}_Z \cdot d\bar{l} = \frac{n2\pi}{M} .\quad (2.18)$$

Here M is the mass of the super fluid particle (He^4 or the Cooper pair formed by two He^3 atoms), g_Z is the gauge coupling of the Z^0 gauge interaction ($g_Z^2 = e^2/\sin\theta_W\cos\theta_W$) and Q_Z is Z^0 charge of the super fluid particle. Q_Z is defined as the expectation value over the spin degrees of freedom

$$\begin{aligned}Q_Z &= \langle I_L^3 - pQ_{em} \rangle , \\ p &= \sin^2(\theta_W) .\end{aligned}\quad (2.19)$$

The values of Q_Z for quarks and electron at rest are

$$Q_Z(u) = \frac{1}{4} - \frac{2p}{3}, \quad Q_Z(d) = -\frac{1}{4} + \frac{p}{3}, \quad Q_Z(e) = -\frac{1}{4} + p. \quad (2.20)$$

From these one obtains the values of Q_Z for proton and neutron: $Q_Z(p) = 1/4 - p$ and $Q_Z(n) = -1/4$ respectively. The values of Q_Z for He^4 and He^3 are

$$Q_Z(^4He) = -\frac{1}{2}, \quad Q_Z(^3He) = -\frac{1}{4}. \quad (2.21)$$

If the magnetic flux associated with Z^0 magnetic field vanishes one obtains the standard formula for the quantization of the velocity circulation of the super fluid. The expression for the penetration depth of the Z^0 magnetic field reads as

$$\lambda^2 = \frac{2M}{N_s Q_Z^2 g_Z^2}. \quad (2.22)$$

The order of magnitude of λ is of the order of $10^{-5} - 10^{-6}$ meters in accordance with the basic assumption $\xi \sim 10^{-6}$ meters for the scale at which classical Z^0 force becomes important. In this formula N_s is the entire super fluid density (essentially Z^0 charge density) and the formula makes sense at the condensation level at which the nuclei feed their Z^0 charges. At the higher condensate levels n , one must replace the density with the actual density of Z^0 charge $N_s \rightarrow N_s / \sqrt{\epsilon_Z(n)}$ (due to the neutrino screening $\epsilon_Z(n)$ is rather large number).

It will found that this generalization implies considerable differences between TGD based and standard descriptions of the super fluidity. For example, the counter part of the magnetic flux quantum is predicted and is a good candidate for the elementary excitation leading to the dissipative super fluid flow at critical velocity considerably smaller than that associated with the known elementary excitations.

2.4 Dissipation in super fluids: critical velocities

Dissipation, or equivalently the loss of the quantum coherence results, when the lifetimes of the bonds connecting neighbouring field quanta are short and the joining and the splitting of the bonds provides the needed dissipation mechanism. One mechanism leading to a loss of the quantum coherence is thermal noise: the critical temperature has been already evaluated. In case of super conductors (super fluids) also external magnetic (Z^0 magnetic) fields lead to a loss of the quantum coherence: the values of the critical magnetic fields can be evaluated for the super conductors of type II and super fluids from the quantization condition. At a high enough flow velocity, the generation of the elementary excitations of the supra phase leads to dissipation. The estimates for the orders of magnitude for the critical velocities for the setup of the dissipation will be derived and are correct in both cases.

2.4.1 Critical velocity for super fluids

The so called Principle of Super Fluidity provides an explanation for the critical velocity of the Super fluid [23]. The application of the energy and momentum conservation to the emission of elementary excitation of energy ϵ and momentum p by flow implies the condition $v \geq \epsilon/p$ and therefore the critical velocity is given by the formula

$$v_L = \text{Min}\left\{\frac{\epsilon}{p}\right\}. \quad (2.23)$$

In case of the super conductors the formula gives $v_L = \Delta(T)/k_F$ (Δ is the energy gap associated with the Cooper pair and k_F is Fermi momentum): the order of magnitude is correct. In case of Super fluids the critical velocities deduced from the roton and phonon spectrum (239 m/s and 58 m/s

respectively) are several orders of magnitude larger than the velocities $v_{cr} \simeq 6 \cdot 10^{-3}$ meters), where the dissipation is known to set up. Velocity vortex predicts a critical velocity, which is too large by an order of magnitude. The hitherto unsolved problem is to identify the excitations giving rise to the dissipation in the supra flow.

The TGD based candidate for the excitation is Z^0 magnetic flux quantum. Z^0 magnetic flux quantum can appear at the condensate level with $L(n) \geq 10^{-6}$ meters to which nuclei feed their Z^0 charges so that the super fluid flow (typically rotating vessel) must have size scale much larger than this length scale. Both hydrodynamic and magnetic excitations are vortex like structures and in order to estimate orders of magnitude they can be idealized as straight vortices with a cylindrical symmetry, possessing Z^0 magnetic field in the direction of the vortex and rotational velocity field (to be studied in detail in the next section).

A general order of magnitude estimate for the critical velocity is obtained by assuming that at velocities higher than the critical velocity the kinetic energy of the supra phase goes to the energy of the excitation in question. The criticality criterion states that $dE_K(R)/dl$, the kinetic energy of the supra flow per unit length of the vortex of radius R and $dE_{ex}(R)/dl$, the energy of the excitation per unit length of the vortex, are identical:

$$\frac{dE_K(R)}{dl} = \frac{dE_{ex}(R)}{dl} .$$

This implies for the critical velocity the expression

$$v_{cr} = \sqrt{\frac{2}{NM\pi R^2}} \sqrt{\frac{dE_{ex}(R)}{dl}} . \quad (2.24)$$

Let us consider now in more detail the magnetic and hydrodynamic vortices.

a) Z^0 magnetic flux quantum

For the Z^0 magnetic flux quantum it is natural to assume that the core of the vortex corresponds to $n_1 \neq 0$ excitation since the requirement that no magnetic field is present implies $n_2/n_1 = \omega_2/\omega_1$ so that both n_2 and n_1 must be non-vanishing. A reasonable idealization for the vortex core is as a cylinder of radius ξ . Inside the vortex core the order parameter of the supra phase is constant so that the condition

$$\oint \bar{v} \cdot d\bar{l} - \frac{Q_Z g_Z}{M_4} \oint \bar{A}_Z \cdot d\bar{l} = 0 , \quad (2.25)$$

holding true for the ground states described by covariantly constant order parameter, is appropriate. The general quantization condition allows $n \neq 0$ but this implies singular velocity in the core of the vortex so that it will be dropped from consideration.

Since $B_Z = B_Z^0$ is constant, one can solve \bar{v}

$$v = \frac{g_Z Q_Z B_Z^0}{2M_4} \rho . \quad (2.26)$$

The core rotates like a rigid body and the rotation frequency is just the rotation frequency of Z^0 charged particle in Z^0 magnetic field. $\nabla^2 B_Z = 0 \neq B_Z/\lambda^2$ so that the matter inside the vortex core is not in supra phase.

Outside the vortex core the conditions

$$\begin{aligned} \oint \bar{v} \cdot d\bar{l} - \frac{Q_Z g_Z}{M_4} \int B_Z da &= \frac{n2\pi}{M_4} , \\ \nabla^2 B_Z &= \frac{B_Z}{\lambda^2} . \end{aligned} \quad (2.27)$$

are satisfied.

Both Z^0 magnetic and velocity fields decay exponentially. At large distances one obtains flux quantization and the constant value of B_Z inside the vortex core is fixed by the flux quantization condition:

$$B_Z^0 = \left[-2 \int_{\xi}^{\infty} B_Z \rho d\rho + \frac{2n}{g_Z Q_Z} \right] \frac{1}{\xi^2} . \quad (2.28)$$

For order of magnitude purposes one can use the approximation

$$B_Z^0 \simeq \frac{2n}{q_Z Q_Z \lambda^2} . \quad (2.29)$$

Since the magnitude of B_Z^0 is quantized in integer multiples, all values of n are possible.

There are two contributions to the energy density of the flux quantum. The energy E_B of the Z^0 magnetic field and the kinetic energy T_{rot} of the rotating super fluid particles. The latter contribution is negligible ($T_{rot}/E_B \simeq (\xi/\lambda)^2$) so that it is enough to consider the magnetic energy density. Since B_Z is largest in the core of the vortex the most conservative form for the criterion is obtained by requiring that the kinetic energy density $T_K = N_s M_4 v^2/2$ of the super fluid flow equals to the Z^0 magnetic energy density $E_B = B_Z^2/2$ inside the core. This condition gives the following expression for the critical velocity

$$v_{cr}(magn) = \frac{B_Z^0}{\sqrt{N M_4}} \simeq g_Z Q_Z \sqrt{\frac{N_s}{M_4^3}} . \quad (2.30)$$

Substituting the typical value of N_s : $N_s \simeq 10^{28.5}/m^3$ one finds $v_{cr} \simeq 10^{-3}$ m/s. The value of the critical velocity is indeed known to be few millimeters in second [23, 20]!

b) Hydrodynamic vortices

The velocity field of the vortex behaves as k/ρ , where $k = n2\pi/M$ is the quantized vorticity. The kinetic energy of the vortex is of the order of $M_4 k^2 \ln(\lambda/\xi)/2$ so that that one obtains for the critical velocity the expression

$$v_{cr}(hydro) \simeq \sqrt{2} \ln(\lambda/\xi) v_{cr}(magn) . \quad (2.31)$$

Substituting the numerical values of the parameters, one finds that the numerical factor is of the order of ten so that hydrodynamic critical velocity is too large by an order of magnitude [23, 20].

2.4.2 Critical velocities for the super conductors

To derive the critical velocities for the super conductors of type II one can apply considerations formally identical with the previous ones. The structure of the magnetized vortices is similar to that of Z^0 magnetized vortices and at the critical velocity the kinetic energy density of the super conducting phase must be identical to the magnetic energy density of $n_1 = 1$ excitation:

$$\frac{n_s m_e \beta_c^2}{2} = \frac{B_c^2}{2} . \quad (2.32)$$

Using the expression for the number density of the super conducting electrons $n_s = \frac{m_e}{e^2 \lambda^2}$ one gets

$$\beta_c = \frac{B_c \lambda e}{m_e} . \quad (2.33)$$

Using the estimate for B_c one obtains $\beta_c \simeq \frac{\sqrt{4\pi}}{m_e \lambda}$ for the super conductors of type II. The order of magnitude obtained, typically 10^2 m/s, is correct [23]. For super conducting elements of type I β_c is considerably smaller since both the critical field and λ are smaller: the order of magnitude is few meters per second and considerably smaller than the critical velocity v_L obtained from the Landau criterion.

2.5 Meissner effect

Meissner effect is one of the basic effects of super conductivity and it is of interest to find the TGD based description of the effect and how Meissner effect generalizes to the super fluid phase.

2.5.1 Meissner effect in superconductors

Meissner effect differs for the super conductors of type I and II. For super conductors of type I, the external field penetrates the whole super conductor if it has strength larger than the critical strength B_c . For super conductors of type II the external magnetic field begins to penetrate after having reached certain critical value B_{c_1} and total penetration takes place at considerably larger value of B_{c_2} . The penetration takes place as flux quanta

$$\int B \cdot da = \frac{m\pi}{e} , \quad (2.34)$$

where m is integer. This condition follows from the general quantization conditions provided the velocity of the super conducting charge carriers vanishes for large distances from the core of the magnetic flux quantum.

The TGD inspired model for the Meissner effect is based on the following observations.

1. The study of the simple models for the topological field quanta to be carried out later shows that in the supra phase topological field quanta have vanishing magnetic vacuum quantum numbers (n_1, n_2) and that there is a nontrivial magnetic field associated with $(n_1, n_2) \neq (0, 0)$ excitations of the topological field quanta. Magnetic field is in the direction of the quantization axis and is approximately constant for a cylindrically symmetric field quantum. The flux of this magnetic field is also quantized by purely topological reasons.

For $(n_1 = 0, n_2 \neq 0)$ magnetic field is also non-vanishing and this field doesn't cut the bonds between the field quanta so that one could in principle construct a magnetic field in super conductor using these excitations. If, however, the condition

$$k \equiv \frac{\omega_2}{\omega_1} \ll 1 , \quad (2.35)$$

holds true, then the flux associated with $(n_1 \neq 0, n_2 = 0)$ is much smaller than for $n_1 = 0$ excitations and it is energetically more favorable to excite $n_1 \neq 0$ excitations so that super conductivity is lost. The study of the simple models for field quanta shows that the assumption that ω_1 has same value for all supra phases, implies this condition.

2. The flux of the critical magnetic field is typically of the order of 10^{-2} Tesla and the flux of B_{c_2} over the field quantum of radius $\xi \simeq 10^{-7}$ m is considerably smaller than the quantized value of the magnetic flux for the super conducting elements (mostly of type I).
3. Since λ is much smaller than ξ for super conductors of type I, the magnetic flux associated with the magnetic vortex is smaller than the quantized magnetic flux, which together with the quantization condition implies that the velocity associated with the vortex cannot approach zero in large distances so that the kinetic energy of the vortex is large and this kind of excitation is not energetically favorable in case of the super conductors of type I. Rather, the magnetic field penetrates as $n_1 \neq 0$ excitation into each topological field quantum separately and as a result the bonds between field quanta are destroyed in the directions transversal to the magnetic field and supra phase is destroyed. For the super conductors of type II λ is large as compared to the radius of the vortex core and magnetic field can penetrate in the form of the flux quanta.

These observations suggest the following description of the Meissner effect.

a) Meissner effect for the super conductor of type I

Magnetic field penetrates into super conductors of type I as topologically nontrivial ($n_1 = 1 \neq 0$) excitations of the individual field quanta (see Fig. 2.5.1). The critical magnetic field is just that associated with $n_1 = 1$ excitation and the penetration of the magnetic field tends to destroy the bonds between the neighbouring field quanta since Φ becomes necessarily discontinuous on the bond. The bonds in the direction of \vec{B} form an exception and might well survive. A structure consisting of topologically condensed cylinder like structures (see Fig. 2.5.1) results. That super conductivity disappears totally is suggested by the observation that $\Lambda = 0$ inside these structures and by the fact electrons rotate in the magnetic field.

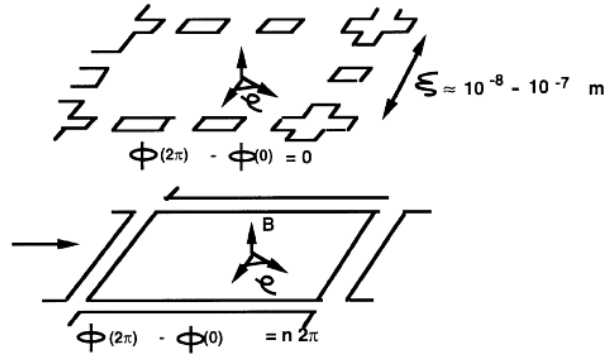

Figure 3: The penetration of magnetic field into a super conductor of type I

The quantization of the magnetic flux takes place in case of Super conductors of type I, too, but the unit is now defined by B_c and smaller than the standard unit. The requirement that the magnetic field associated with the $n_1 = 1$ field quantum equals to B_c gives condition on the vacuum parameters of type I super conductor.

It would be nice if one could estimate the value of the critical magnetic field or equivalently, the value of the magnetic field associated with the $n_1 = 1$ excitation. The prediction is possible provided one can estimate the values of the vacuum quantum numbers associated with the imbedding of Kähler electric field of matter: in the next section this kind of estimate is carried out.

b) Meissner effect for the super conductor of type II

Magnetic field penetrates into super conductors of type II as approximately cylindrical field quanta. The core of the cylinder corresponds to a topological field quantum of radius of order ξ , which has suffered topologically nontrivial ($n_1 \neq 0$) excitation. Since the flux associated with $n = 1$ quantum is considerably smaller than that required by the quantization of magnetic flux, an exponentially damped magnetic field is created in the surrounding field quanta. This field corresponds to a topologically trivial deformation ($n_1 = 0!$) in the dependence of Φ on the M^4 coordinates and therefore the bonds connecting nearby neighbours are not destroyed and this region corresponds to a supra phase. The quantized magnetic flux is essentially given by the region surrounding the core.

The value of the critical magnetic field B_{c_1} can be estimated by noticing that the external magnetic field decomposes into field quanta with the property that the total flux of field quanta is same as that associated with the external field. This gives

$$B = n_v \frac{\pi}{e} , \quad (2.36)$$

where n_v is the number of flux quanta per unit area. As an estimate for n_v one can take $n_v \simeq 1/\pi\lambda^2$, so that one obtains the estimate

$$B_{c_1} \simeq \frac{1}{e\lambda^2} . \quad (2.37)$$

The order of magnitude is about 10^{-1} Tesla for $\lambda \simeq 10^{-7}$ m: for Nb , which is the only superconducting element of type II the order of magnitude for critical magnetic field is indeed this [23]. The value of the magnetic field associated with $n = 1$ excitation cannot be very much larger than this field. It is natural to identify B_{c_2} as the magnetic field associated with $n_1 = 1$ excitation and so that the previous estimate combined with the estimate for B_1 gives $B_{c_2} \simeq 2B_{c_1}$.

Notice that the proposed model explains why ferromagnetic materials cannot be superconducting provided one can assume that the condition $k \ll 1$ holds true generally (ω_1 depends only weakly on material).

2.5.2 Meissner effect for super fluids

TGD predicts that Meissner effect is possible for super fluids, too and that super fluids are completely analogous to superconductors of type II. The magnetic vortices in the super fluid correspond to the quanta of the Z^0 magnetic flux.

The critical value of B_Z cannot be obtained directly from the experiment. The critical value of B_Z can be estimated by generalizing the formula of B_c for superconductors of type II and the formula for the penetration length λ

$$\begin{aligned} B_c^Z &\simeq \frac{1}{Q_Z g_Z \lambda^2} , \\ \lambda^2 &= \frac{2M}{Q_Z^2 g_Z^2 N_s} , \end{aligned} \quad (2.38)$$

where M is the mass of the super fluid particle and g_Z is Z^0 coupling constant and N_s the number density of the super fluid particles.

Superfluid should prohibit the penetration of Z^0 magnetic field created by some external source by creating surface flow. The obvious question is whether one can imagine any experimental tests for the prediction. To get grasp of the situation one can consider the following simple experimental arrangement.

A cylinder containing super fluid is surrounded by a rotating cylinder (see Fig. 2.5.2). The rotation of the outer cylinder creates Kähler magnetic and therefore also Z^0 magnetic field. Meissner effect implies that a surface flow is generated on the boundary of the super fluid vessel possessing direction opposite to that of rotation. A related effect would be the penetration of the Z^0 magnetic field in the form of vortices creating visible hydrodynamic vortices in the liquid. Unfortunately, the Z^0 field in question is extremely weak (for ordinary vacuum quantum numbers) so that the surface flow needed to cancel the Z^0 magnetic field is very small and might imply that the effect is not observable. Also the penetration of the field in the form of vortices is very improbable since penetration takes place only above some critical field strength, which is quite large.

Consider next a simple quantitative model for the situation. The constant axial Kähler magnetic field created by the rotating outer cylinder is given by the expression

$$\begin{aligned} B_{out}^K &= \epsilon_1(out) N_{out} \Omega_{out} S_{out} , \\ S_{out} &= \pi(R_1^2 - R_0^2) , \end{aligned} \quad (2.39)$$

where S_{out} denotes the cross-sectional area of the outer cylinder with the inner radius R_0 and outer radius R_1 and rotating with the angular velocity Ω_{out} .

The constant axial magnetic field created by a surface current of thickness λ rotating around the superfluid cylinder of radius R is given by

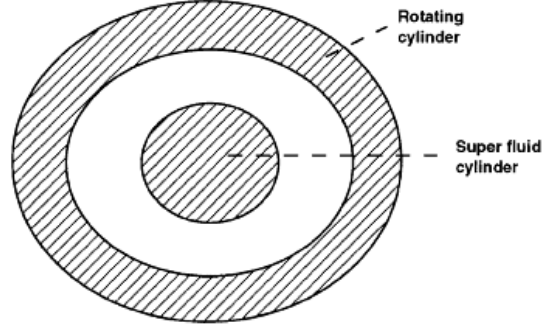

Figure 4: Experimental arrangement demonstrating Meissner effect for Super fluids

$$\begin{aligned} B_{in}^K &= \epsilon_1(in) N_s \Omega_{in} S_{in} , \\ S_{in} &= \pi(R^2 - (R - \lambda)^2) , \end{aligned} \quad (2.40)$$

where N_s denotes the density of the super fluid particles and Ω_{in} is the rotation velocity of the super fluid flow.

These fields must cancel each other inside the super fluid so that a condition for the ratio of rotation frequencies results

$$\begin{aligned} \frac{\Omega_{in}}{\Omega_{out}} &= \frac{\epsilon_1(out) N_{out} S_{out}}{\epsilon_1(in) N_s S_{in}} \\ &\simeq \frac{\epsilon_1(out) N_{out} R_1^2}{\epsilon_1(in) N_s 2R\lambda} , \end{aligned} \quad (2.41)$$

where the assumption $R_1 \gg R_0$ is made. An order of magnitude estimate for Ω_{in} is obtained using magnitudes $R_1 = 1 \text{ m}$, $R = 10^{-3} \text{ m}$, $\lambda \simeq 10^{-5} \text{ m}$ and $\Omega_{out} \simeq 10^3/s$. The Z^0 current fed from the “previous” condensate level serves as source of Z^0 magnetic field at level n since neutrinos do not participate in the flow. The estimate for the the ratio of parameters $\epsilon_1(n_Z)$ is obtained as follows: at nuclear condensate level one has $\epsilon_1 \sim 10^{19} g_Z$ (no screening) and at the condensate level n_Z one has $\sqrt{\epsilon_Z(n_Z)} \sim 10^{10} - 10^{11}$ from the estimate to be carried out in next subsection, which gives $\epsilon_1(out) \in 10^8 g_Z - 10^9 g_Z$. This gives

$$\Omega_{in} \sim 10^{-10} \frac{N_0}{N_s} \Omega_{out} \geq \frac{1}{200 \text{ minutes}} , \quad (2.42)$$

for $\epsilon_Z = 10^{11}$. Whether the existence or nonexistence of this kind of effect could be determined experimentally remains an open question.

2.5.3 Rotating super fluid

In the two fluid theory the condition that super fluid flow is irrotational ($\nabla \times \bar{v} = 0$) seems to exclude the rigid body rotation of the super fluid. On the average super fluid phase is however known to rotate like rigid body [23, 20] and the problem is to explain this result.

a) Hydrodynamic vortices

The generally accepted resolution of the difficulty [23] is that super fluid flow decomposes into hydrodynamic vortices, with the property that the flow is irrotational inside the vortices except in

the core of the vortex where super fluid density vanishes: this is achieved if the velocity is given by $v = k/\rho$. The requirement that super fluid wave function is single valued, implies the quantization of the circulation for the vortex

$$\oint \bar{v} \cdot d\bar{r} = \frac{n2\pi}{M} ,$$

implying the condition $k = n/M$. Vortices in turn form a regular array, which rotates like a rigid body. The average vorticity per surface area is given by $n_v k$, where k must be same as the vorticity of the rigid body rotation: this gives for the density of vortices the expression

$$n_v(\text{hydro}) = \frac{2\Omega}{2\pi k} = \frac{\Omega M_4}{\pi} . \quad (2.43)$$

The vortex core, where super fluid density vanishes according to the conventional theory, should have radius $\rho_0 \simeq 10^{-10} m$. Although the vortices as such are not visible there is indirect experimental evidence for the existence of the vortex like structures, in particular for the existence of vortex cores [23, 20] possessing inner core radius of order $10^{-10} m$.

The generation of the vortices should begin at some critical angular velocity Ω (the circulation of the rigid body flow being of the order of the quantum of circulation at this value of Ω : this kind of effect has indeed been observed: the critical velocity is however smaller than the predicted one [23]).

One can wonder what happens at the rotation velocities smaller than the critical one. Does super fluid flow like a rigid body or does it rotate at all? There is some experimental evidence supporting the view that super fluid does not rotate for sufficiently low rotation velocities so that the behavior is analogous to Meissner effect with Ω playing the role of the magnetic field.

b) Z^0 magnetic vortices

Consider now an alternative TGD inspired description of the situation. The problem is clearly created by the velocity circulation condition, which implies that supra flow is irrotational almost everywhere. In TGD approach the quantization condition however contains also the contribution of the Z^0 magnetic flux besides the velocity circulation so that there is no reason to require that velocity field has vanishing curl anymore! Assuming that super fluid flows as rigid body one can adjust B_Z so that the quantization condition is satisfied.

$$B_Z = \frac{2\Omega M_4}{g_Z Q_Z} . \quad (2.44)$$

The resulting field is rather weak as compared to the critical B_Z . Ω must be of the order of $10^7/s$ (ten orders of magnitude larger than the critical rotation velocity for the formation of vortices!) to guarantee that B_Z is equal to the critical B_Z . This suggests that B_Z vortices cannot appear at rotation velocities studied and that the generation of the velocity vortices is the correct solution of the problem.

There are also other counter arguments. First, since the required field is much smaller than the critical field it seems impossible to imbed this magnetic field into super phase (one should excite some topological field quanta to $n_1 \neq 0$ state). Secondly, the generation of the subcritical magnetic field is excluded by the Meissner effect. Thirdly, $\nabla^2 B_Z = 0 \neq B_Z/\lambda^2$ so that super phase would be destroyed if constant B_Z is generated. On the other hand, the solution has the nice feature that the rigid body rotation of the super fluid could be regarded as a direct experimental evidence for the existence of macroscopic Z^0 field.

One manner to escape these problems is to argue that B_Z is constant in average sense only and that the actual field is consists of a network of Z^0 magnetic flux quanta in rigid body motion. The requirement that the total flux over the cross section of the container is same as the flux of constant field gives for the density of magnetic flux quanta per unit area the expression

$$n_v(\text{magn}) = \frac{\Omega M_4}{\pi} . \quad (2.45)$$

The density is identical with that obtained for hydrodynamical vortices! This observation suggests the solution to the discrepancy and a more detailed mechanism for the destruction of superfluidity. Superfluidity is destroyed, when Z^0 magnetic field (created by rotating Z^0 charge density) at condensation level $n_1 > n_Z$ ($L(n_Z) \sim 10^{-6} m$) penetrates to the level n_Z in form of flux quanta with strength B_c^Z . The conservation of magnetic flux explains why the average field strength at the level n_Z is identical with the penetrating field strength at the level n_1 . Since Z^0 charge current of the previous level serves as source of Z^0 magnetic at level n one obtains as a byproduct an estimate for the value of $\epsilon_Z(n_Z)$ from the formula 2.38 for the critical Z^0 magnetic field strength giving $\sqrt{\epsilon_Z(n_Z)} \sim 10^{10}$ and $\epsilon_1 \sim 10^9 g_Z$ so that neutrino screening of Z^0 charge at level n_Z is rather effective.

Which of the mechanisms is correct or are both mechanisms at work? In order to answer this question one should verify experimentally whether the vortices observed in a rotating super fluid are really velocity vortices or Z^0 magnetic vortices or both. Since the critical velocity for the Z^0 magnetic vortices is smaller than for the hydrodynamical vortices, one might argue that at critical angular velocity Z^0 magnetic vortices appear and hydrodynamic vortices appear for larger angular velocities. Some indirect support for the TGD based scenario indeed exists. The study of the rotating ${}^3\text{He}$ has demonstrated that the angular velocity Ω and ordinary magnetic field B play very similar physical role in the texture of the rotating ${}^3\text{He}$ and that the texture of ${}^3\text{He}$ is rather sensitive to both these parameters. In TGD picture one can replace Ω and B by B_Z and B and a rich structure of the quantized excitations is predicted.

2.6 Phase slippage

The so called phase slippage [16] provides a mechanism for the dissipation in the case of superfluids. Also this phenomenon has natural interpretation in terms of the flux quantization. The conventional description of the phase slippage is in terms of angle like order parameter χ . For linear flow the order parameter behaves linearly as a function of the coordinate x in the direction of the flow

$$\chi(x) = kx, \quad (2.46)$$

where k can be interpreted as the momentum of the super fluid particle.

In the phase slippage the graph of $\chi(x)$ as a function of x is deformed so that χ jumps by an integer multiple of 2π at some point x_0 and stays linear for $x \leq x_0$ and for $x \geq x_0$. The value of k must however decrease for $x \geq x_0$ and this means that the momentum of the super fluid particle decreases and dissipation occurs. Since the discontinuity is multiple of 2π the graph can be replaced with a new one without any discontinuity and smoothed out so that the graph of χ is linear with new value of the momentum k . The change in the momentum k is quantized:

$$\Delta k = n \frac{2\pi}{L}, \quad (2.47)$$

where L is the length of the channel. The process corresponds physically to the propagation of the vortex generated at the wall of the channel across the channel under the action of Magnus and friction forces and the integer n associated with the vortex ($\chi = n\phi$) equals to the integer associated with the Δk .

The process has obvious geometric interpretation in TGD approach. The angles Ψ and Φ are the counterparts of the angle like order parameter χ and phase slippage corresponds to the propagation of a vortex ($r = 0$ at the axis of the vortex and $r = \infty$ at the surface of the vortex) through the channel. In general the vortex is characterized by two integers n_1 and n_2 . It has been already shown that the ordinary hydrodynamical dissipation and generation of turbulence might be understood in terms of the phase slippage process: the only difference with respect to the super fluidity is that the integers n_i and frequencies ω_i are much larger now: ordinary hydrodynamical system is obtained from the super fluid in the limit of the large quantum numbers.

3 Models for the topological field quanta

In the sequel simple models for the electromagnetic and Z^0 gauge fields created by condensed matter are studied. The aim is to get some grasp on the physically reasonable values of the vacuum parameters

appearing in the imbedding by using as experimental input the values of coherence length ξ and critical magnetic fields. Two kinds of imbeddings are studied.

1. Spherically symmetric, electrovac imbedding of Z^0 condensate levels $n \geq n_Z$) or ordinary electric field (condensate levels $n < n_Z$) created by matter serves as a simple model for the topological field quanta in the ordinary condensed phase.
2. Cylindrically symmetric field quantum serves as an idealization for the linear structures obtained by glueing spherically symmetric topological field quanta together using joining along boundaries operation and is interesting as a model for the core of various vortex like structures. Several imbeddings of this kind are constructed.
 - i) An imbedding of cylindrically symmetric em/Z_0 electric field for matter at rest is constructed assuming that matter density serves as the source of em/Z_0 electric field.
 - ii) By applying a boost in the direction of cylinder axis an imbedding of the em/Z_0 magnetic field associated with say super fluid flow is obtained.
 - iii) Allowing non-vanishing quantum numbers n_i an imbedding of a constant Z^0/m magnetic field in the direction of the cylinder axis is obtained. The requirement that the magnetic flux of this field is quantized in the standard manner, poses an additional condition on the vacuum parameters. One can construct ordinary magnetic fields in the length scales $n \geq n_Z$ as deformations of Z^0 electric field configuration. As a consequence of the construction procedure, the critical radius of all these imbeddings depends on the properties of the matter only.

The dependence of the critical radii on the vacuum quantum numbers is studied and estimates for the vacuum numbers of topological field quanta are deduced. Ordinary phase with $\omega_1 \sim m_0 \sim 10^{-4} m_{Pl}$ is shown to correspond to the large quantum number limit in the sense that the critical radii are macroscopic and therefore also magnetic flux m as well as the quantum numbers ω_i and n_i are very large. The imbedding of the magnetic field is obtained nonperturbatively in the sense that the change Δn_i needed to generate the magnetic field satisfies the condition $\Delta n_i/n_i \gg 1$.

Supra phases correspond to the small quantum number limit and to Z^0 neutral space-times: using ξ and B_c as inputs, it is found that the parameter ω_1 is of the order of $10^{2.5} - 10^3$ proton masses. The assumption that ω_1 is same for all super conductors implies $\omega_2/\omega_1 \ll 1$, which condition in turn is necessary condition for Meissner effect to take place. The value of the fractal quantum number m is assumed to be zero for 4He and -2 for the other supra phases. the non-vanishing value of m affects radically the value of ϵ_1 so that estimates have considerable uncertainties.

3.1 The Kähler field created by a constant mass density

In the following the em/Z^0 electric field created by an Z^0/em neutral, constant mass distribution assuming that mass distribution serves as a source of pure em/Z^0 field proportional to Kähler field, are studied. Although the mass distribution itself is homogeneous, Kähler electric field necessarily breaks translational symmetry. Concerning the applications in mind, the breaking of the translational symmetry to the spherical or cylindrical symmetry is the most natural one and will therefore be considered in the sequel. Also the imbedding of a spherically (cylindrically) symmetric Kähler electric field can break spherical (cylindrical symmetry) since several gauge potentials are possible by gauge invariance and different gauges are related by the canonical transformations of CP_2 and correspond to different four-surfaces: it is assumed however that imbedding is spherically (cylindrically) symmetric, too. What makes the cylindrically symmetric field configuration so interesting is that one can construct several physically interesting field configurations from it by modifying the values of the vacuum quantum numbers so that electrovac conditions cease to hold true.

To begin with, recall the conditions guaranteing the vanishing of either Z^0 or electromagnetic gauge fields

$$\begin{aligned} r &= \tan(X) \ , \quad \Psi = k\Phi \ , \\ X &= \frac{\ln(|(u+k)/C|)\epsilon}{2} \ . \end{aligned} \tag{3.1}$$

One must chose the branch of arcus tangent in the expression of X in terms of r and this implies the condition $m\pi \leq X \leq (2m+1)\pi/2$, where m is an integer fixing the branch of the arcustangent and will be referred to as euantum number. The following remarks are useful for what follows:

1. The vanishing of the Z^0 field is achieved for

$$\epsilon = \epsilon(em) = \frac{1}{2} ,$$

and the vanishing of the electromagnetic field is achieved for

$$\epsilon = \epsilon(Z) = \frac{(3+p)}{(3+2p)} ,$$

($p = \sin^2(\theta_W) \simeq 0.234$).

2. The CP_2 projection of the imbedding is two-dimensional, which implies the orthogonality of the magnetic and electric fields belonging to same condensate level. Z^0/em field is proportional to induced Kähler form for the imbeddings in question

$$\begin{aligned} \gamma &= k_{em}J = a_{em}\sin^2 X du \wedge d\Phi , \\ k_{em} &= 3 , \quad a_{em} = -\frac{3}{4} , \\ Z^0 &= k_Z J = a_Z \sin^2 X du \wedge d\Phi , \\ k_Z &= \frac{6}{p} , \quad a_Z = -\frac{3}{3+p} . \end{aligned} \tag{3.2}$$

One consequence of $F_{em} = 3J$ is that the # throats feeding magnetic flux to/from a purely electromagnetic condensate level behave on given space-time sheet as magnetic monopoles with magnetic charge quantized in multiples of the magnetic charge associated with the ordinary Dirac monopole: what is peculiar is that the magnetic charge is divisible by 3. As quantum effects are considered the # throats behave as extremely tiny magnetic dipoles.

3. Electromagnetic/ Z^0 charge density of matter is assumed to serve as source of em/Z^0 fields and in the idealization that matter consists of identical nuclei (A, Z) one can write the charge density as

$$\begin{aligned} \rho_{em} &= \frac{e^2}{\sqrt{\epsilon_{em}}} \frac{Z}{A} N = K_{em} N , \\ \rho_Z &= -\frac{g_Z^2}{4\sqrt{\epsilon_Z}} \frac{A-Z}{A} N = K_Z N , \end{aligned} \tag{3.3}$$

where N is the density of the nucleons. It has been assumed that only neutrons contribute to the nuclear Z^0 charge.

The formulas associated with the spherically and cylindrically symmetric imbeddings differ from each other by numerical factors only and the cylindrically symmetric case will be considered first. Assuming cylindrical symmetry em/Z^0 electric field is radial and its magnitude is given by

$$\begin{aligned} |E_\rho^{em}| &= \delta K_{em} \frac{N\rho}{2} , \\ |E_\rho^Z| &= \delta K_Z \frac{N\rho}{2} , \\ \delta &= 1 , \end{aligned} \tag{3.4}$$

The numerical factor δ is introduced in order to generalize the results to spherically symmetric case easily.

Cylindrically symmetric imbedding of the em/Z^0 electric field is obtained through the ansatz

$$\begin{aligned}\Phi &= \omega_1 t , & \Psi &= \omega_2 t , & u &= u(\rho) , \\ k &= \frac{\omega_2}{\omega_1} .\end{aligned}\tag{3.5}$$

One can define $\omega_1 = m_p \sqrt{\epsilon_i} x$, where x is numerical factor not very far from unity in astrophysical scales. The dependence of u on ρ is fixed from the imbeddability condition for the appropriate electric field

$$\begin{aligned}\frac{a_i}{k_i} \sin^2 X \partial_\rho u \omega_1 &= \delta K_i N \frac{\rho}{2} , \\ i &= em, Z^0 .\end{aligned}\tag{3.6}$$

From this expression one can integrate u as a function of ρ

$$\int_{u_0}^u \sin^2(X(u)) du = \delta \frac{K_i k_i}{a_i \omega_1} N \rho^2 .\tag{3.7}$$

This equation determines the value of the critical radius of the imbedding as a function of u_0 , the value of u at $r = \infty$ surface provided $u = 0$ at $r = 0$ surface. Performing the integral, one obtains the condition

$$\begin{aligned}\rho_{cr} &= \sqrt{\frac{2a_i \omega_1}{\delta K_i k_i N}} \sqrt{2(u_0 + k)} \exp(-m\pi/\epsilon(i)) X(\epsilon(i)) , \\ X(\epsilon) &= \sqrt{\frac{(2 + \epsilon^2) \exp(\pi/\epsilon) + \epsilon^2}{(1 + \epsilon^2)}} , \\ i &= em, Z^0 .\end{aligned}\tag{3.8}$$

Here u_0 is the value of $u = \cos(\Theta)$ at the axis of the vortex ($k = \omega_2/\omega_1$) and various parameters with index i are defined in the previous formulas.

The general orders of magnitude become clear, when one writes the formula in a numerical form by using the density $N_0 = 10^{30}/m^3$ is a reference density of atomic nuclei.

1. In electromagnetic case one obtains

$$\begin{aligned}\rho_{cr} &\simeq X \cdot 3.7 \cdot 10^{-6} \text{ meters} , \\ X &= \sqrt{(u_0 + k)} \sqrt{\epsilon_{em} x} \sqrt{\frac{A N_0}{Z N}} \frac{1}{\sqrt{\delta}} 10^{-2.7288m} , \\ \omega_1 &= \sqrt{\epsilon_{em} x m} (\text{proton}) .\end{aligned}\tag{3.9}$$

The critical radius for spherically symmetric imbedding is obtained by replacing $\delta = 1$ with $\delta = 2/3$.

2. In Z^0 case one obtains

$$\begin{aligned}\rho_{cr} &\simeq X \cdot 7.75 \cdot 10^{-7} \text{ meters} , \\ X &= \sqrt{(u_0 + k)} \sqrt{\epsilon_Z x} \sqrt{\frac{A N_0}{(A - Z) N}} \frac{1}{\sqrt{\delta}} 10^{-1.46m} , \\ \omega_1 &= \sqrt{\epsilon_{em} x m} (\text{proton}) .\end{aligned}\tag{3.10}$$

for $p = \sin^2(\theta_W) = 1/4$.

The previous formulas contain still unknown parameters $(u_0 + k, x)$ but order of magnitude estimates are possible for the critical radius since the value of $u_0 \leq 1$ is not expected to be anomalously small.

For the em neutral space-time there are two especially interesting special cases.

1. For $\sqrt{\epsilon_Z} \sim 10^{18}$ (so that Z^0 force is of the same order of magnitude as gravitational force) and for $m = 0$ critical radius is about $10^{11} m$, which is roughly the size of the solar system.
2. For $\sqrt{\epsilon_Z} \sim 10^{10}$ (level n_Z) and for $m = 0$ one has $\rho_{cr} \sim 10^3 m$ in typical condensed matter densities.

For Z^0 neutral space-time expected to be important in subcellular length scales $m = 0, x = 1$ and $\epsilon_{em} = 1$ (no charge screening by electrons) the critical radius is about 10^{-6} meters. If one assumes $\omega_1 = \epsilon_{em} m_e x$ (replacing $m(\text{proton})$ by m_e) with $x \sim 1$ one obtains critical radius of order $10^{-8} - 10^{-7}$ meters, which is of same order of magnitude as characteristic length parameters for super conductors. Same is achieved by assuming $m = -1$ instead of $m = 0$.

Critical radius depends exponentially on the value of the integer m and the imbeddings with different values of m are related by a discrete scale transformation $\rho_{cr} \rightarrow \exp(-m\pi/\epsilon)\rho_{cr}$: the "fundamental" change of scale is given $\exp(\pi/\epsilon) \simeq 28.9$ in the electromagnetically neutral case (note the dependence on $\sin^2(\theta_W)$) and by 535.5 in the Z^0 neutral case. Of course, it is not at all obvious whether the scaled up surfaces are structurally stable.

Using the BCS expression and TGD based estimate for the binding energy of the Cooper pairs, one obtains the formula

$$\rho_{cr} \simeq \frac{1}{\sqrt{m_e \Delta}} \exp\left(\frac{1}{N(0)V}\right), \quad (3.11)$$

which gives relationship between vacuum parameters and parameters of BCS model [23].

3.2 The imbedding of a constant magnetic field

The imbedding of constant em/Z^0 magnetic field is obtained from the corresponding electric field associated with the constant mass density assuming that Ψ and Φ depend also on the angle ϕ

$$\begin{aligned} \Phi &= \omega_1 t + n_1 \phi, & \Psi &= \omega_2 t + n_2 \phi, & u &= u(\rho), \\ k &= \frac{\omega_2}{\omega_1} = \frac{n_2}{n_1}. \end{aligned} \quad (3.12)$$

The condition $n_2/n_1 = k$ guarantees electromagnetic neutrality. Magnetic fields are in the direction of the z-axis and their magnitudes are given by the expression

$$\begin{aligned} |B_i| &= \left| \frac{n_1 E_i}{\omega_1 \rho} \right| = \frac{n_1 N}{\omega_1} \delta \frac{K_i}{2}, \\ i &= em, Z^0. \end{aligned} \quad (3.13)$$

and are indeed constant.

The magnetic flux associated with the topological field quantum is in the electromagnetic case given by

$$\Phi = \int B_{em} da = -n_1 \frac{3}{4} (u_0 + k) \exp(-4m\pi) \frac{(9\exp(2\pi) + 1)}{5} \pi. \quad (3.14)$$

The quantization of the magnetic flux gives a condition for the parameters u_0 and k . The requirement that the flux is quantized in multiples of the elementary flux quantum irrespective of the value of n_1 implies the condition

$$\frac{3}{4}(u_0 + k)exp(-4m\pi) \frac{(9exp(2\pi) + 1)}{5} = \frac{1}{n} ,$$

$$n = 1 . \quad (3.15)$$

The more general condition $n > 1$ corresponds to the assumption that n_1 is multiple of n .

Applying this condition to the expression for the critical radius, one has

$$\rho_{cr} = \sqrt{\frac{A}{Z}} \sqrt{\epsilon_{em} x} \sqrt{\frac{2}{e^2} \frac{m(\text{proton})}{N}} \frac{1}{\sqrt{n}}$$

$$\sim \sqrt{\frac{A}{Z}} \sqrt{\epsilon_{em} x} \frac{1}{\sqrt{n}} \cdot 1.6 \cdot 10^{-7} \text{ meters} ,$$

$$B^{em} = \frac{2n_1}{\rho_{cr}^2} = 2n_1 n \frac{Z}{A} \frac{e^2}{2\epsilon_{em} x} \frac{N}{m(\text{proton})} . \quad (3.16)$$

The requirement that the radius of the flux quantum is of order $10^{-8} - 10^{-7}$ meters (magnetic penetration length for the super conductor) gives in $n = 1$ case the estimate $\sqrt{\epsilon_{em} x} \sim 1$ at the condensation level in question. Since $\epsilon_{em} \geq 1$ holds true this means that $x < 1$ must hold true. An alternative possibility is that $n > 1$ holds true instead of $n = 1$. The third possibility is that the imbeddability condition gives only an upper bound for the critical radius and that stability conditions give additional constraints. An additional restriction for the values of the free parameters comes from the requirement that the critical magnetic field ought to be of the order of $B_{cr} \simeq 10^{-2}$ Tesla for the super conductors of type I and larger for the super conductors of type II. The critical magnetic field obviously corresponds to the smallest possible magnetic field allowed by the flux quantization and this estimate does not give anything new at order of magnitude level.

The quantization of the Z^0 magnetic flux gives

$$a_Z(u_0 + k)exp(-2m\pi/\epsilon(Z))C(\epsilon(Z)) = \frac{1}{n} ,$$

$$n = 1 , \quad (3.17)$$

and reduces the expression for the critical radius and magnetic field to the form

$$\rho_{cr} = \sqrt{\frac{A}{(A-Z)}} \sqrt{\epsilon_Z x} \sqrt{\frac{8}{g_Z^2} \frac{m(\text{proton})}{N}} ,$$

$$B^Z = \frac{2n_1}{\rho_{cr}^2}$$

$$= n_1 n \frac{(A-Z)}{A} \frac{g_Z^2}{4\epsilon_Z x} \frac{N}{m(\text{proton})} , \quad (3.18)$$

completely analogous to the expressions deduced in the electromagnetic case.

In $n > n_Z$ case Z^0 magnetic fields are expected to dominate over the Z^0 electric fields: the reason is that the screening neutrinos probably do not contribute to the Z^0 gauge current density acting as the source of Z^0 magnetic field but contribute to Z^0 charge density causing a very effective screening. This means that the source of Z^0 magnetic field at level n corresponds to the Z^0 charge density (and ϵ_Z) associated with level $n - 1$. In particular, at level n_Z there is no screening for Z^0 magnetic field. For $n > n_Z$ one can generate approximately constant ordinary magnetic fields by giving up the condition $n_2/n_1 = \omega_2/\omega_1$. The expression for the magnetic field strength is given by

$$|B^{em}| = \frac{(3+p)(3+2p)}{6} B^Z$$

$$= 2n_1 \frac{(3+p)(3+2p)}{6} \frac{(A-Z)}{A} \frac{g_Z^2}{8\epsilon_Z x} \frac{N}{m(\text{proton})} ,$$

$$p = \sin^2(\theta_W) , \quad (3.19)$$

where the quantization condition for Z^0 flux is used (the least one can hope is that one might fix the orders of magnitudes correctly for free parameters). At the level $n = n_Z$ one can generate fields of order one Tesla (Tesla corresponds roughly to $N/m(\text{proton})$) at small quantum number limit ($\epsilon_Z(n_Z - 1) = 1$). At the next level the field of one Tesla requires $n_1 \sim 10^{20}$ for $\epsilon_Z x \sim 10^{20}$ so that large quantum number limit is in question.

3.3 Magnetic fields associated with constant velocity flows

One can construct a simple candidate for the Kähler magnetic field associated with a fluid flow with a constant velocity by boosting the cylindrically symmetric Kähler electric field in the direction of the cylinder axis:

$$\begin{aligned}\Phi &= \omega_1 t + k_1 z, & \Psi &= \omega_2 t + k_2 z, & u &= u(\rho), \\ k_i &= \omega_i \beta.\end{aligned}\tag{3.20}$$

The field lines are circles around the z-axis and the strength of the Kähler magnetic and Z^0 magnetic fields are given by

$$\begin{aligned}|B_K| &= \left| \frac{k_1}{\omega_1} E_K \right|, \\ B_Z &= \frac{3}{\sin^2(\theta_W)} B^K.\end{aligned}\tag{3.21}$$

Super fluid flow is a natural application for this mechanism for generating magnetic field. In this case the cylindrical symmetry of the Kähler electric field is indeed very natural. Note that although the flux tubes are in the direction of the flow the critical radius doesn't depend on the flow velocity.

In order to obtain non-vanishing magnetic field (associated, say, with super conducting current) one must give up the condition that the field is obtained by a boost. For example, one can assume that $k_1 \neq \omega_1 \beta$. An interesting possibility is that the magnetic field associated with the super conducting current is obtained in this manner. It should be noticed that one can obtain also helical magnetic fields by performing boost to a configuration with non-vanishing magnetic field.

4 Quantum Hall effect from topological field quantization

The concept of the topological field quantum and the ideas about the formation of macroscopic quantum systems and about the topological description of the dissipation provide a classical TGD based description of Quantum Hall effect very similar to that found for supra phases.

4.1 The effect

Consider first briefly the effect. The effect is observed two-dimensional systems consisting of a conducting slab in a strong magnetic field perpendicular to the slab. When potential difference V is applied in the y-direction of the slab (see Fig. 4.1), the Lorentz force induces a transversal current. The current is proportional to the electric field associated with the potential:

$$j_x = \sigma_{xy} E_y,\tag{4.1}$$

where σ_{xy} is the transversal conductivity.

Two kinds of effects have been observed at low temperatures ($T \simeq 1\text{ K}$) and using strong magnetic fields $B \simeq 10\text{ T}$.

1. In integer quantum Hall effect σ_{xy} is quantized in units of the fine structure constant

$$\sigma_{xy} = n \times 2\alpha,\tag{4.2}$$

where n is integer.

2. In the fractional quantum Hall effect σ_{xy} is quantized in fractional units

$$\sigma_{xy} = \frac{n}{m} \times 2\alpha , \quad (4.3)$$

where the integer m is fixed. Several values of m have been found to be possible.

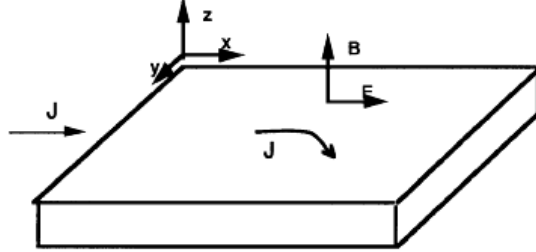

Figure 5: Quantum Hall effect

4.2 The model

One can understand Quantum Hall effect in TGD framework using the following arguments.

4.2.1 Conduction electrons as a mesoscopic quantum system

Assume that in the Quantum Hall phase conduction electrons form a mesoscopic quantum system, which means that topological field quanta with size of the order of $\xi \simeq 10^{-8} - 10^{-7}$ meters are glued together by join along boundaries bond to form a lattice like structure. The bonds must be stable since otherwise their splitting and rejoining causes an additional dissipation contributing to the transversal conductivity and Quantum Hall effect is lost. The estimate for the critical temperature $T_c \simeq 1/2m_e\xi^2$ used for the supra phases applies also now and correctly gives $T_c \simeq 1$ K.

4.2.2 How to avoid the splitting of the joining along boundaries bonds in a strong magnetic field

Since a strong magnetic field (of the order of few Tesla) is present, individual topological field quanta are excited to $(n_1, n_2) \neq 0$ states. There are *two* possible manners to avoid the breaking of the bonds between the neighbouring topological field quanta:

1. The condition $n_1 = 0$ is satisfied for all topological field quanta. $n_1 = 0$ field quanta are favored if the condition

$$k \equiv \omega_2/\omega_1 \gg 1 , \quad (4.4)$$

is satisfied so that $n_2 = 0$ quanta have much larger magnetic flux than $n_1 = 0$ field quanta. If $k \gg 1$ condition is satisfied, the magnetic field inside the flux quantum can change in discrete, but sufficiently small, steps, when external magnetic field is varied. For the values of the vacuum quantum numbers encountered for the supra phases, the value of n_2 ought to be rather large, of the order of 10 – 100 in Quantum Hall phase. A possible problem of this scenario is that the flux associated with the $n_1 = 1$ quantum is of same order as the flux of the external magnetic field: why this excitation is not generated?

The $k \ll 1$ condition encountered in the case of supra phases leads to difficulties. The magnetic field associated with $n_1 = 0$ excitations is large and of the order of the external magnetic

field if same values for vacuum quantum numbers are assumed as for the supra phases so that external could excite these excitations. The problem is that the magnetic field associated with $n_1 \neq 0$ excitations is much smaller and its is difficult to understand why the variation of the external magnetic field does not not excite them (with the consequence that Quantum Hall phase disappears).

2. The condition $u = \cos(\Theta) = \pm 1$ is satisfied on the $r = \infty$ boundaries of the field quanta. In this case both n_1 and n_2 can vary freely. For the magnetic fields used and for the values of parameters found for supra phases n_1 should be of the order of $n_1 = 1$ and n_2 can have much larger values. This makes possible the variation of the magnetic flux inside the field quantum in discrete steps, the step being however reasonably small. Thus it seems that this alternative is the physical one.

4.2.3 Quantization conditions

Assume that the quantization conditions

$$\int \bar{B}_{em} \cdot d\bar{a} - m \oint \bar{v} \cdot d\bar{l} = \frac{m \times 2\pi}{qe} , \quad (4.5)$$

encountered in the case of the supra phases are satisfied in Quantum Hall phase, too. Since the magnetic flux inside the topological field quanta is quantized in multiples of certain basic unit associated with n_1 , which is much smaller than the standard flux quantum, the velocity field must adjust itself inside each flux quantum so that the quantization condition is satisfied. This is achieved if the velocity field is a super position of two terms

$$\bar{v} = \bar{v}_0 + \bar{v}_{rot} , \quad (4.6)$$

where \bar{v}_0 is essentially constant velocity field associated to the Hall current and \bar{v}_{rot} is a local velocity field inside the topological field quantum, whose function is to cancel the failure of the magnetic field to satisfy the standard flux quantization condition

$$m_e \oint \bar{v}_{rot} \cdot d\bar{l} = -\frac{m2\pi}{qe} + \int \bar{B}_{em} \cdot d\bar{a} \equiv -\int \Delta\bar{B} \cdot d\bar{a} . \quad (4.7)$$

Here \bar{v}_{rot} corresponds to a rigid body rotation in the constant magnetic field $\Delta\bar{B}$, which is the difference between the actual field and the field for which magnetic flux is quantized in standard units. Obviously, the external magnetic field must be so strong that the flux through a topological field quantum is of the order of the field quantum: otherwise unrealistically large local velocities are needed to guarantee quantization condition (or m would be equal to zero).

4.2.4 Carriers of the Hall current as an incompressible 2-dimensional liquid

Assume that the carriers of the Hall current behave like an incompressible, two-dimensional liquid (this assumption is made in the competing models, too [18]). Assume also that the Euler equations are satisfied and write them into the following form

$$n_e m_e \frac{\partial \bar{v}}{\partial t} = -\nabla p - n_e m_e \nabla \left(\frac{v^2}{2} \right) + n_e m_e \bar{v} \times (\nabla \times \bar{v}) + n_e qe (\bar{E} + \bar{v} \times \bar{B}) . \quad (4.8)$$

Here n_e is the number of Hall current carriers per unit area orthogonal to the direction of magnetic field and m_e is the mass of the current carrier (electron).

4.2.5 Stationary state

The stationary situation for which the velocity can be decomposed in the manner already described is characterized by the conditions

$$\begin{aligned}
 \bar{v} &= \bar{v}_0 + \bar{v}_{rot} , \\
 \frac{\partial \bar{v}}{\partial t} &= 0 , \\
 \nabla[p + n_e m_e (\frac{v^2}{2} - \frac{v_{rot}^2}{2})] + X &= 0 , \\
 X &\equiv n_e q e \bar{v}_{rot} \times \bar{B} .
 \end{aligned}
 \tag{4.9}$$

The remaining equation leads to the formula for transversal conductivity

$$n_e m_e \bar{v}_0 \times (\nabla \times \bar{v}_{rot}) + q e n_e \bar{E} + q e n_e \bar{v}_0 \times \bar{B} = 0 .
 \tag{4.10}$$

Before deriving the expression for the transversal conductivity it is useful to verify that the solution ansatz works. One can substitute to the quantity $X \equiv \bar{v}_{rot} \times \bar{B}$ the expression of \bar{v}_{rot} obtained from quantization condition (rigid body rotation) and one finds that this term is also expressible as a gradient: $X = a \nabla(B^2 \rho^2)$, where a is some numerical constant. This implies that second condition reduces to a condition of form

$$p + n_e m_e (\frac{v^2}{2} - \frac{v_{rot}^2}{2}) + n_e q e a B^2 \rho^2 = p_0 = \text{constant} .
 \tag{4.11}$$

This condition is a local condition referring to the properties of the flow inside the topological field quanta and is not essential for Quantum Hall effect.

4.2.6 Hall current

In order to obtain expression for the Hall current one can integrate the third condition involving Lorentz force over a transversal (orthogonal to B) surface area associated with one or more topological field quanta. One obtains the following expression for the Hall current $\bar{j}_H = q e n_e \bar{v}_0$

$$\begin{aligned}
 j_H &= \sigma_{xy} E , \\
 \sigma_{xy} &= -e \frac{\int n_e da}{(\int \bar{B} \cdot d\bar{a} - m_e \oint \bar{v} \cdot d\bar{l})} .
 \end{aligned}
 \tag{4.12}$$

Same expression can be obtained also directly from the Euler equations under much milder assumptions by integrating the x - component of the equations over the surface area. All the terms in Euler equation and not appearing in the formula for the Hall current ($\nabla v^2, \nabla v_{rot}^2, \nabla p, \bar{v}_{rot} \times \bar{B}$) give vanishing contribution to the integral over the field quantum provided they correspond to the variations of the physical quantities, whose average vanishes in length scales larger than the size of the topological field quantum.

One can write this formula in a form exhibiting fractional Quantum Hall effect by noticing that the integral $\oint n_e da$ is just n_{free} , the number of the carriers of Hall current inside the topological field quantum (or the several of them) and is quantized! The general quantization condition in turn implies that the denominator is integer multiple of $2\pi/qe$. What one obtains is the following formula for the transversal conductivity

$$\sigma_{xy} = -\frac{n_{free} e^2}{m 2\pi} .
 \tag{4.13}$$

One obtains integer quantum Hall effect for $m = 1$ and fractional quantum Hall effect for $m \geq 1$.

4.2.7 Comments

Some comments concerning the proposed scenario are in order.

1. For a macroscopic quantum system consisting of a very large number of the topological field quanta n_{free} and m are so large that the value of the conductivity is practically continuous without any further assumptions. If one however assumes that the values of m and the number of the free charge carriers are same for all topological field quanta then it is possible to realize the situation, where n_{free}/m can be written as a ratio of small integers.
2. All integer values for m (in accordance with the experimental facts!) are possible (not only odd integers as in case of the anyon super conductivity in its simplest version [22]). m corresponds to the angular momentum of an electron rotating around the flux tube in accordance with the Laughlin's proposal for the state functions of charge carriers [22]. Since $m = 1$ angular momentum is expected to be most probable in low temperatures and for low magnetic fields, fractional quantum Hall effect is expected to be more rare phenomenon than integer Hall effect.
3. When magnetic field is kept as constant and potential V is varied the number of the free charge carriers inside the flux quantum changes in discrete steps at some critical values of the potential so that plateaus of σ_{xy} result. When magnetic field is varied compensating, velocity fields inside the field quanta are generated in order to preserve the quantization condition. When magnetic field is suitable, a change in the vacuum quantum number n_2 and possibly n_1 takes place and the rotational velocity field \bar{v}_{rot} goes to zero. This doesn't lead to a change of the transversal conductivity in general. When total magnetic flux becomes sufficiently near to its quantized value also the integer m characterizing the flux quantum can change so that the fractional number characterizing quantum Hall effect changes. This kind of a transition can be regarded as a phase transition taking place in the whole specimen.
4. The proposed explanation differs from the more standard explanations in some respects.
 - i) The concept of fractional filling fractions follows from the quantization conditions and from the concept of the topological field quantum.
 - ii) No reference is made to fractional statistics or to fractional electric charges.
 - iii) The situation $m = 0$ is particularly interesting physically. In this case the transversal Hall conductivity is formally infinite. The only reasonable solution of the Euler equation in this case seems to be that for which the velocity in the transversal direction vanishes so that Hall effect and magnetic field is effectively absent (!) and classically (probably not quantum mechanically) there is a continuous acceleration in the direction of the electric field. Clearly the slab behaves as a super conductor apart from the presence of \bar{v}_{rot} term in velocity.
 - iv) The standard models for the fractional Quantum Hall effect predict also super conductivity together with the breaking of CP invariance. In present case the presence of the classical Z^0 electric vacuum fields suggests small parity breaking. This effect takes however place in ordinary supra phases, too and possibly in all condensed matter systems.

5 TGD and condensed matter

In previous sections we have applied TGD to a rather exotic condensed matter phenomena. Quite contrary to the original expectations it has turned out that TGD might have applications to less exotic condensed matter phenomena, too. In fact, it seems that TGD might be applied to reformulate the description of conductors, di-electrics, and magnetism using topological concepts.

5.1 Electronic conductivity and topological field quantization

The standard Drude model for conductors [21] starts from the equilibrium condition $dv/dt = v/\tau - eE/m_e = 0$ to derive the expression for the conductivity of a metal as $\sigma = Ne^2\tau/m_e$. τ is interpreted as the average time between two collisions and is obtained from the estimate $\tau \simeq a/v_{th}$, where a is the distance between atoms and v_{th} is thermal velocity. The estimate is by a factor $10^2 - 10^3$ too small at low temperatures and approaches the observed conductivity at high temperatures only. A correct order of magnitude estimate is obtained if a is replaced with the size $\xi \simeq 10^{-8} - 10^{-7}$ meters

of topological field quantum in accordance with the idea that ordinary metal behaves as a super conductor at length scales smaller than ξ . The decrease of the conductivity at higher temperatures can be understood, too: the joining along boundaries bonds between atoms become more and more unstable as the temperature is increased.

5.2 Dielectrics and topological field quantization

Why do electrons then move freely in length scales smaller than ξ ? This can be understood by introducing a TGD based description of a dielectric to be discussed in more detail later. The point is that there are two condensation levels present. This means that the electric flux D (electric displacement) associated with a test charge divides into two parts. First part P (polarization) flows at the first level of the condensate (in particular along the bonds joining topological field quanta of atomic size). Second part E (electric field) flows at the background space-time, which corresponds to a larger space-time sheet. Since total electric flux is conserved, the fractions of electric flux sum up to one: $1/\varepsilon_1 + 1/\varepsilon_2 = 1$ ($D = E + P$), where the fractions are defined in terms of the dielectric constants ε_1 and ε_2 associated with the two levels of condensation. For an ideal conductor all electric flux runs to the larger space-time sheet and there are no electric fields at the first level of the condensate: electrons move freely! For an ideal dielectric all electric flux flows at the first level of condensation and strong electric fields are associated with the join along boundaries bonds.

5.3 Magnetism and topological field quantization

Same kind of argumentation should work in case of magnetism, too. The magnetic flux H created by a test current can be decomposed to two parts. The first part M (magnetization) flows through the first level of the condensate and second part B (magnetic field) flows through the larger space-time sheet. Again one can associate susceptibilities μ_1 and μ_2 ($\mu_1 + \mu_2 = 1$) to both levels of the condensate to describe the properties of a simple magnetic substance.

The mechanism underlying spontaneous magnetization is not very well understood [20, 17, 21] and an interesting question is whether the magnetic domains in the spontaneous magnetization could be understood using TGD based concepts. The quantization of the field strength for a flux quantum implies that macroscopic magnetization results if the magnetic fields of $n_1 \geq 0$ excitations associated with these flux quanta are oriented in parallel. From the known values of the magnetic fields in ferromagnets and from the sizes of the magnetized domains it is possible to estimate the values of ω_1 and the fractal quantum number m . The typical values of the magnetic fields are of the order of 10^{-2} Tesla and stable domains of magnetization are known to have size of the order of 10^{-8} meters. The fact that the orders of magnitude are same as for super conductors suggests that the sizes of the topological field quanta do not depend strongly on the properties of the condensed matter system.

In the phenomenological theory of the ferromagnetism the so called Weiss molecular field appears [21]. If this field is present then the magnetic moments of individual electrons are oriented parallel and magnetization is essentially the density of the magnetic moments per volume: $M \propto N_e \mu_e$. The problem is that this field is very large, having magnitude of the order of 10^3 Tesla, which is about 10^5 times large than the actual magnetic field!

Standard explanation is that this field is only an effective field giving a short hand description of essentially quantum level phenomena (so called exchange interaction between electrons, which favors parallel spins for the electrons of the neighboring atoms). A possible TGD based classical explanation is that there is indeed magnetic field of this strength present. This field is present at the "zerth" level of condensation that is inside the field quanta having atomic size (which are glued together by the join along boundaries bonds). Again the field strength is quantized and flux quantum is related by the scaling factor $(\xi_1/\xi_0)^2 \simeq 10^4 - 10^6$ to the magnetic field quantum at the first condensation level. The order of magnitude is indeed correct!

References

Online books about TGD

- [1] M. Pitkänen (2006), *Topological Geometroynamics: Overview*.
http://tgd.wippiespace.com/public_html/tgdview/tgdview.html.
- [2] M. Pitkänen (2006), *Quantum Physics as Infinite-Dimensional Geometry*.
http://tgd.wippiespace.com/public_html/tgdgeom/tgdgeom.html.
- [3] M. Pitkänen (2006), *Physics in Many-Sheeted Space-Time*.
http://tgd.wippiespace.com/public_html/tgdclass/tgdclass.html.
- [4] M. Pitkänen (2006), *Quantum TGD*.
http://tgd.wippiespace.com/public_html/tgdquant/tgdquant.html.
- [5] M. Pitkänen (2006), *TGD as a Generalized Number Theory*.
http://tgd.wippiespace.com/public_html/tgdnumber/tgdnumber.html.
- [6] M. Pitkänen (2006), *p-Adic length Scale Hypothesis and Dark Matter Hierarchy*.
http://tgd.wippiespace.com/public_html/paddark/paddark.html.
- [7] M. Pitkänen (2006), *TGD and Fringe Physics*.
http://tgd.wippiespace.com/public_html/freenergy/freenergy.html.

Online books about TGD inspired theory of consciousness and quantum biology

- [8] M. Pitkänen (2006), *Bio-Systems as Self-Organizing Quantum Systems*.
http://tgd.wippiespace.com/public_html/bioselforg/bioselforg.html.
- [9] M. Pitkänen (2006), *Quantum Hardware of Living Matter*.
http://tgd.wippiespace.com/public_html/bioware/bioware.html.
- [10] M. Pitkänen (2006), *TGD Inspired Theory of Consciousness*.
http://tgd.wippiespace.com/public_html/tgdconsc/tgdconsc.html.
- [11] M. Pitkänen (2006), *Mathematical Aspects of Consciousness Theory*.
http://tgd.wippiespace.com/public_html/genememe/genememe.html.
- [12] M. Pitkänen (2006), *TGD and EEG*.
http://tgd.wippiespace.com/public_html/tgdeeg/tgdeeg/tgdeeg.html.
- [13] M. Pitkänen (2006), *Bio-Systems as Conscious Holograms*.
http://tgd.wippiespace.com/public_html/hologram/hologram.html.
- [14] M. Pitkänen (2006), *Magnetospheric Consciousness*.
http://tgd.wippiespace.com/public_html/magnconsc/magnconsc.html.
- [15] M. Pitkänen (2006), *Mathematical Aspects of Consciousness Theory*.
http://tgd.wippiespace.com/public_html/magnconsc/mathconsc.html.

References to the chapters of books

- [A1] The chapter *An Overview about the Evolution of TGD* of [1].
http://tgd.wippiespace.com/public_html/tgdview/tgdview.html#tgdevoI.
- [A2] The chapter *The chapter An Overview about Quantum TGD* of [1].
http://tgd.wippiespace.com/public_html/tgdview/tgdview.html#tgdevoII.

- [E9] The chapter *Topological Quantum Computation in TGD Universe* of [5].
http://tgd.wippiespace.com/public_html/tgdnumber/tgdnumber.html#tqc.
- [F6] The chapter *Topological Condensation and Evaporation* of [6].
http://tgd.wippiespace.com/public_html/paddark/paddark.html#padaelem.
- [F8] The chapter *TGD and Nuclear Physics* of [6].
http://tgd.wippiespace.com/public_html/paddark/paddark.html#padnucl.
- [F9] The chapter *Dark Nuclear Physics and Living Matter* of [6].
http://tgd.wippiespace.com/public_html/paddark/paddark.html#exonuclear.
- [J6] The chapter *Coherent Dark Matter and Bio-Systems as Macroscopic Quantum Systems* of [9].
http://tgd.wippiespace.com/public_html/bioware/bioware.html#darkbio.

Condensed matter physics

- [16] Anderson, P., W. (1966), *Rev. Mod. Phys.* 38, 298.
- [17] Brown, W., F. (1963): *Micromagnetics*, John Wiley & Sons.
- [18] Chakrabarty, T. and Pietiläinen, T. (1988): *The Fractional Quantum Hall Effect*, Springer Verlag.
- [19] Ginsberg, D., M. (ed.)(1989,1990): *Physical Properties of High Temperature Super Conductors*, vols I and II, World Scientific, Singapore.
- [20] Goodstein, D., L. (1975): *States of Matter*, Prentice-Hall, Inc..
- [21] Guinier, A. and Julien, R. (1987): *The Solid State: From Superconductors to Superalloys*, Oxford University Press.
- [22] Mackenzie, R. and Wilczek, F. (1988), *Rev. Mod. Phys.*, A3, p.2827.
- [23] Tilley, D., R. and Tilley, K. (1986): *Super Fluidity and Super Conductivity*, Adam Hilger Ltd..